

Eddystone

1650/9
RECEIVER

INSTALLATION NOTES OPERATING INSTRUCTIONS AND SERVICE DATA

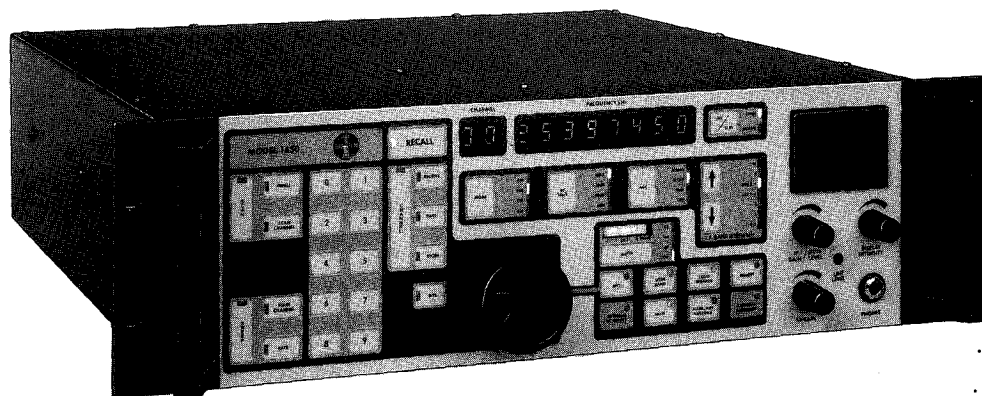

Eddystone Radio

A MARCONI COMMUNICATION SYSTEMS COMPANY



Eddystone Radio Limited,
Eddystone Works,
Alvechurch Road, Birmingham B31 3PP, England.
Telephone: 021-475 2231
Telex: 337081
Facsimile: 021-477 5224

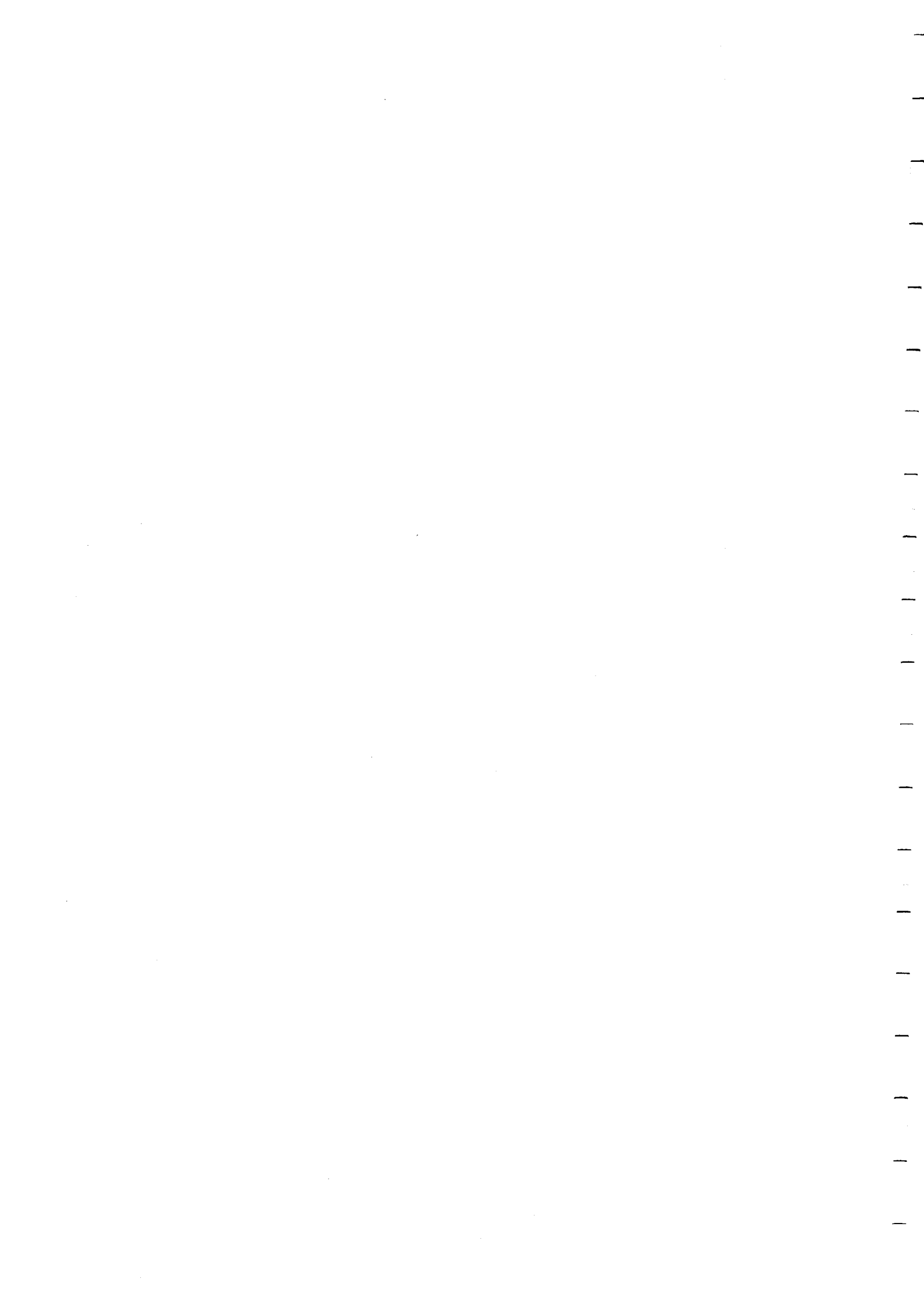

1650/9 HANDBOOK INDEX

SECTION ONE : INTRODUCTION (White Pages)

1.1 GENERAL DESCRIPTION.....	Page 1
1.2 DATA SUMMARY.....	Page 3

SECTION TWO : INSTALLATION (Gold Pages)

2.1 PHYSICAL DIMENSIONS AND FITTINGS.....	Page 1
2.1.1 Accessories Kit.....	Page 1
2.1.2 Rack Mounting.....	Page 2
2.1.3 Bench Mounting.....	Page 2
2.2 EXTERNAL CONNECTIONS.....	Page 5
2.2.1 A.C. Mains Input Connector.....	Page 5
2.2.2 D.C. Supply Connector.....	Page 6
2.2.3 Ancillaries Connector.....	Page 6
2.2.4 Remote Control Connections.....	Page 8
2.2.5 Antenna Switch.....	Page 11
2.2.6 Aerial Input Connector.....	Page 12
2.2.7 IF Output (High Level).....	Page 12
2.2.8 IF Output (Low Level).....	Page 12
2.2.9 External Standard Input.....	Page 12
2.3 SETTING UP PROCEDURES.....	Page 12
2.3.1 A.C. Supply.....	Page 12
2.3.2 Fuses.....	Page 12
2.3.3 Preset Option Selector.....	Page 13
2.3.4 Aerial Voltage Overload Protection.....	Page 14

SECTION THREE : OPERATION (Yellow Pages)

3.1 CONTROLS.....	Page 1
3.1.1 Receiver Operating Mode Keys.....	Page 1
3.1.2 Numerical Keys.....	Page 5
3.1.3 Main (Central) Control Knob.....	Page 6
3.1.4 Channel Data Keys.....	Page 6
3.1.5 Miscellaneous Controls and Displays.....	Page 7
3.2 SIGNAL RECEPTION.....	Page 2
3.2.1 Switching On.....	Page 12
3.2.2 Setting the Tuned Frequency.....	Page 13
3.2.3 Signal Mode Settings.....	Page 15
3.2.5 Audio Mute Operation.....	Page 18
3.2.6 Carrier Operated Relay.....	Page 19
3.2.7 R.F. Selectivity.....	Page 20
3.2.8 Antenna Selection.....	Page 20
3.3 BITE (Built-In-Test-Equipment).....	Page 21
3.3.1 Passive BITE.....	Page 21
3.3.2 Active BITE.....	Page 21
3.4 Channelised Operation.....	Page 27
3.5 Scanning Operation.....	Page 32
3.6 Sweeping Operation.....	Page 37

BOUND AT REAR

Front Panel Layout.....BP2092
Interconnections and Misc. Modules Cct. Diag.....BP1978
Preselector Circuit Diagram.....BP2088
RF and 1st IF Circuit Diagram.....BP2020
Main IF and Audio Circuit Diagram.....BP1976
Synthesiser and VCO Circuit Diagram.....BP2089
Display Board Circuit Diagram.....BP1996
Interface Board Circuit Diagram.....BP1992
16K Microcomputer Circuit Diagram.....BP1953
NBFM Board Circuit Diagram.....BP1977
External Standard Adaptor Circuit Diagram.....BP1712

APPENDIX A (Dark Green Pages)

A.1 COMPONENT HANDLING.....Page 1
A.2 FIRST AID IN CASE OF ELECTRIC SHOCK.....Page 3
A.3 HEALTH AND SAFETY AT WORK ACT (1974).....Page 5

First Edition.....1650/9 Handbook.

June 1988.

SECTION ONE : INTRODUCTION

WARNING

 Before connecting the unit to the power supply, SECTION TWO : INSTALLATION must be read especially with regard to the instructions concerning wiring of the mains connector. Information about first aid in the case of electric shock and about the 'Health and Safety at Work Act 1974 (United Kingdom)' is bound at the rear in Appendix A.

This book is organised in the following sections.

SECTION ONE : INTRODUCTION which includes safety warnings, a general description of the unit, its options and ancillaries and a data summary.

SECTION TWO : INSTALLATION which details physical dimensions and fittings and all external connections. Setting-up procedures and fuse details are also given.

SECTION THREE : OPERATION which describes all the unit's controls and their use (signal reception, BITE, channelised operation, scanning and sweeping).

1.1 GENERAL DESCRIPTION

The Eddystone 1650/9 is a digitally synthesised, high performance, microprocessor controlled receiver covering the range 10kHz to 29999.995kHz with 5Hz resolution. Comprehensive remote and automatic control facilities also allow control using a computer or a dedicated mimic control panel (Eddystone model 1775/9). Eddystone 1760 and 1761 Remote Interface Adaptors enable the receiver to be controlled over RS232 or RS422 links respectively (TTL without R.I.A.s). Complete multi-address remote control systems for up to sixteen receivers can be formed with the addition of Eddystone 1771 and 1774 Multi-address Decoders and Controllers. A wide range of 300 or 1200 Baud asynchronous compatible 'off-the-shelf' modems, line drivers and multiplexers etc. can also be used in the remote control system.

The 1650/9 can be supplied with various options. The options fitted to a particular receiver are indicated by the letters after '1650/9' on the rear panel serial plate. A list of the options is given in Table 1.1.

Table 1.1
1650/9 Options

Suffix	Option
/A	With motor tuned, multi-range, RF narrowband pre-selector
/S	With external standard input (internal link for 1 or 5MHz)
/N	With NBFM reception facilities
/K	With internal FSK demodulator
/P	With panoramic display output

All options are available for any 1650/9 except /N and /K together.

A 1650/9ASN, for example, has the preselector fitted, an external frequency standard input and NBFM reception facilities.

/P receivers can drive the Eddystone 1161 Panoramic Display Unit. It should be noted however that /P receivers have a slightly different performance specification.

As well as comprehensive facilities for the reception of AM, SSB, CW, FSK and NBFM (/N receivers) signals, a 99 channel non-volatile memory is provided for storage of all major receiver settings. These memories can also be scanned as required or used to store the end frequencies for automatic sweep tuning. Audio muting, scan/sweep halt and a carrier operated relay, all with an adjustable threshold level, can be used in conjunction with the scanning and sweeping facilities to control the operation of the receiver and ancillary equipment depending on the input signal level. An extra non-volatile channel memory is provided for direct entry of tuned frequency etc. (the 'free tuning' channel).

Built-In-Test-Equipment (BITE) is provided to monitor and test the signal path and synthesiser circuitry. The information provided assists fault finding to module level.

Rear panel connections are provided for a wide range of ancillary equipment. On all 1650/9 receivers, the high level, 1400kHz I.F. output can be used to drive the Eddystone 1529/2 or 1529/4 FSK demodulators. Optional external standard input (/S) and panoramic drive output (/P) are also available.

As well as the two way control link, the remote control connector provides a serial data output which indicates the present tuned frequency of the receiver. This can be used with ancillary equipment such as R.F. preselectors and panoramic display units which need to know that frequency. Finally, this connector has a hold scan/sweep input line which can be used by external equipment to directly control scanning or sweeping operations, and on /K receivers, it has the demodulated FSK data output (RS232c).

Connections and power supply outputs are provided to select one of up to four external items such as antennas or R.F. preamplifiers. This information can be stored in the channel memories so that antenna switching etc. is done automatically when channels are being scanned.

Audio line and high level outputs, carrier operated relay, external muting, diversity AGC connections etc. are provided on a separate connector.

1.2 DATA SUMMARY

Frequency coverage	10kHz to 29999.995kHz.
Tuning step	Adjustable in range 10Hz to 99.99kHz (10Hz increments). Automatic variable rate can also be set with a minimum step of 5Hz.
Reception modes	AM mode for A2A, A3E. SSB mode for H2A, H3E, R2A, R3E, J2A, J3E. CW mode for A1A. FM mode for F2A, F3E (suffix /N receivers). FM mode for F1B, F1D (suffix /K receivers or any receiver with an external 1529 FSK demodulator). The use of other external demodulators will enable most other signal modes to be received.

Bandwidths	0.3kHz, 1kHz, LSB 2.4kHz, USB 2.4kHz, 3kHz, 8kHz, 16kHz.
Gain control	Audio, slow or fast AGC or manual gain using front panel control. In all cases the antenna attenuator provides up to at least 40-50dB extra manual gain control. A diverstiy AGC link is provided on the rear panel.
B.F.O. range	+/- 3.9kHz in 100Hz steps (CW mode only).
Antenna input	50 Ohm unbalanced, BNC connector. Overload protection is provided for continous application of 30V or 50V emf at input (internal link option). Internal reed relay controlled from associated transmitter interrupts antenna feeder and grounds input circuit during transmission (control can be switch to ground or a positive voltage). I.F. and A.F. desensitising is also provided.
Antenna select	Maximum of four remotely switched units (e.g. antennas) can be selected from the front panel.
R.F. selectivity	Wideband 10kHz to 30MHz filter and, on suffix /A receivers, a motor tuned, multi-range, narrowband R.F. pre-selector.
Muting/COR	Audio muting (and scan/sweep halt) is derived from carrier level on AM, SSB and CW, and from noise or carrier level (internal link option) on NBFM (suffix /N receivers). Carrier level muting can be adjusted from the front panel and also controls the single pole changeover 'carrier operated relay' on all modes including NBFM (either link option). Noise level muting on NBFM is adjusted internally.

Audio outputs	1W maximum into 4 to 8 Ohms external loudspeaker. 150mW maximum into front panel monitor loudspeaker. 20mW maximum into 600 Ohm line. 10mW maximum into low/medium impedance headphones.
I.F.s	46.205MHz first I.F. 1.4MHz second I.F.
I.F. outputs	High level (1.4MHz), 20mV across 50 Ohms with signal in AGC range. Low level (46.205MHz, suffix /P receivers), +10dB above input signal level.
Display	Colour coded light emitting diodes (LEDs). Eight digits for frequency, two for channel number.
Controls	Thirty-four key sealed membrane keyboard with selectable sounder, main control knob and three minor control knobs.
Meter functions	CZ for FM tuning (suffix /N and /K receivers). AF for rear panel line audio output (calibrated 10mW into 600 Ohms). RF for signal level with AGC on (calibrated approximately 0 to 50dBuV emf for zero to full scale deflection). This reads the position of the IF GAIN / MUTE LEVEL control when AGC is off. COR for carrier operated relay etc. threshold level when AGC is on (again calibrated approximately 0 to 50dBuV emf).
BITE	BITE provides continuous fault monitoring and enables a wide range of individual tests to be made, thus assisting fault-finding to module level.

Stored Channels

A maximum of 99 channels can be stored with frequency, mode, bandwidth, AGC, RF sensitivity and remote antenna selection.

An extra stored channel is provided for direct entry of these settings.

Channel contents can be interrogated and changed without interruption of the signal received.

Battery back-up is provided to prevent loss of information in all 100 channels in the event of a power failure.

Scanning

Any number of the 99 stored channels can be automatically or manually scanned with a dwell time on each channel of between 0.1 and 9.9 seconds. If mute is selected, the scan will halt on channels with signals above the set threshold, and remain there for a hang period of between 0 and 9 seconds after the signal ceases. Scanning can also be halted or stepped on using the rear panel hold scan/sweep connection. At all times the scan position can be altered using the main control knob.

Sweeping

Automatic tuning using the selected tuning step can be performed using the frequencies stored in adjacent channel memories as limits. The receiver remains on each step for the selected dwell period. If a step of 5kHz or greater and mute are selected, the sweep will halt on steps with signals above the set threshold, and remain there for a hang period of between 0 and 9 seconds after the signal ceases. Sweeping can also be halted or stepped on using the rear panel hold scan/sweep connection. At all times the sweep position can be altered using the main control knob.

Remote control	All major functions can be controlled using 300 or 1200 Baud asynchronous data at TTL level (RS232c or RS422a using adaptors). An additional serial data output using 2400 Baud asynchronous data is provided to indicate the present tuned frequency of the receiver to ancillary equipment.
Power supplies	100/150V and 200/260VAC (40-60Hz single phase). AC consumption approximately 60VA. Operation from 19-32V DC (negative ground) is automatically selected in the absence of an AC supply. DC current approximately 3.5A maximum.
Environmental	Operational, -15 to +55 deg.C. Storage, -40 to +70 deg.C. Rel. humidity, 95% at 40 deg.C. Bump/vibration, meets MPT1204 and CEPT requirements.
Height	Rack mounting, 133mm (3U). Cabinet mounting, 164mm (inc. feet).
Width	Rack mounting, 483mm (19in). Cabinet mounting, 502mm.
Depth	Rack mounting, 480mm (intrusion into rack). Cabinet mounting, 528mm.
Weight	Rack mounting, approx. 19kg. Cabinet mounting, approx. 23kg.

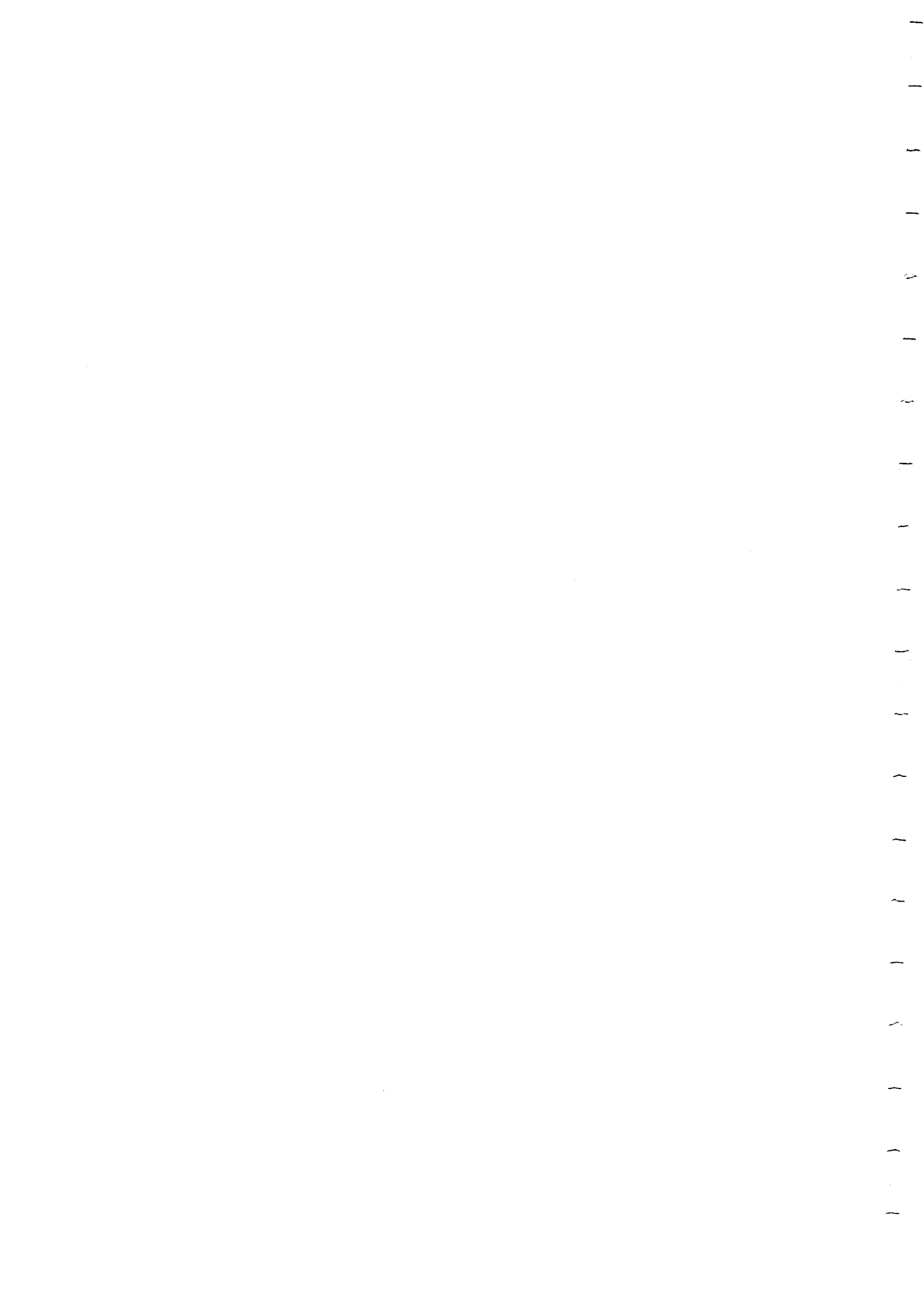

SECTION TWO : INSTALLATION

WARNING

⚠ Before connecting to the power supply, the sub-sections 'EXTERNAL CONNECTIONS - 2.2.1 A.C. Mains Input Connector and 2.3.2 Fuses' must be read.

2.1 PHYSICAL DIMENSIONS AND FITTING

2.1.1 Accessories Kit

A kit of accessories is supplied with the receiver. The contents of the kit should be checked against Table 2.1.

Table 2.1
Contents of Accessories Kit LP4656

Qty	Description	Part No.
1	Mains connector and lead	D4815P
1	4 Way shell (DC supply)	13123P
2	Sockets (DC supply)	13124P
1	25 Way Plug	11153P
1	9 Way Plug	13125P
1	9 Way Socket	11973P
1	25 Way Cover	12877P
2	9 Way Cover	12875P
2	BNC Plugs	8012P
1	6.3A Fuse	12879P
1	3.15A Fuse	11967P
1	1A(T) Fuse	9816P
4*	Cabinet feet (with Screws)	9817P

* Not supplied with rack mounting receivers.

Table 2.2
Accessories Available to Order

Description	Catalogue No.
Cabinet	LP4487
Anti-Vibration Mounting Kit	1547
Cabinet Loudspeaker Unit	1615
Headphones	1588

2.1.2 Rack Mounting

The receiver can be installed directly in 483mm (19 in) racking using four suitable screws. Plain washers or plastic cup washers should be used beneath the screwheads to prevent damage to the paint finish. Fixing slots conform to the standard spacing of 57mm (2.25 in). Overall dimensions of the receiver are shown in Figure 2.1. Rack mounting receivers may easily be converted to bench mounting and vice-versa. The accessories required are listed in Table 2.1.

2.1.3 Bench Mounting

Four mounting feet are included with the accessories kit. These should be fixed to the bottom corners of the cabinet using the four M4 X 10 screws provided. Dimensions of the receiver are shown in Figure 2.1. Anti-Vibration Mountings are available for bench mounting receivers, see Table 2.2. The dimensions of the receiver and cabinet fitted with anti-vibration mountings are shown in Figure 2.1A and fitting is as follows:-

- 1) Remove the cabinet feet.
- 2) If access to the underside of the mounting surface (i.e. the bench or shelf) is available, drill sixteen clearance holes on the centres shown in Figure 2.2 to enable the anti-vibration mountings to be bolted to the surface. If access to the underside is not available these holes must be drilled and tapped to take suitable hexscrews.
- 3) Fix the four anti-vibration mountings to the base of the cabinet using M6 X 20 screws, ensure the bases are correctly aligned.

4) Secure the bases to the mounting surface.

Figure 2.1
Dimensions of Receiver in all mounting styles

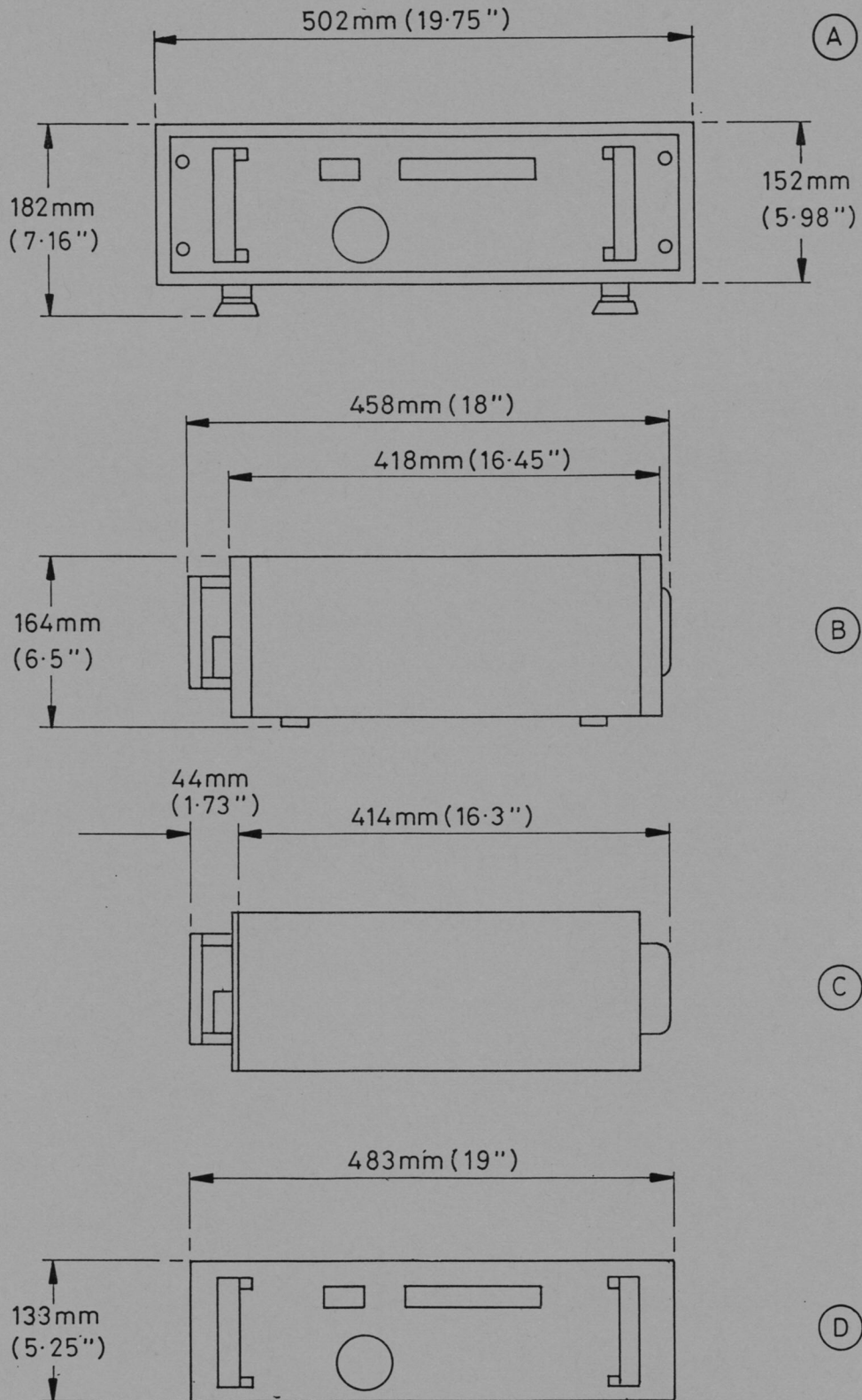
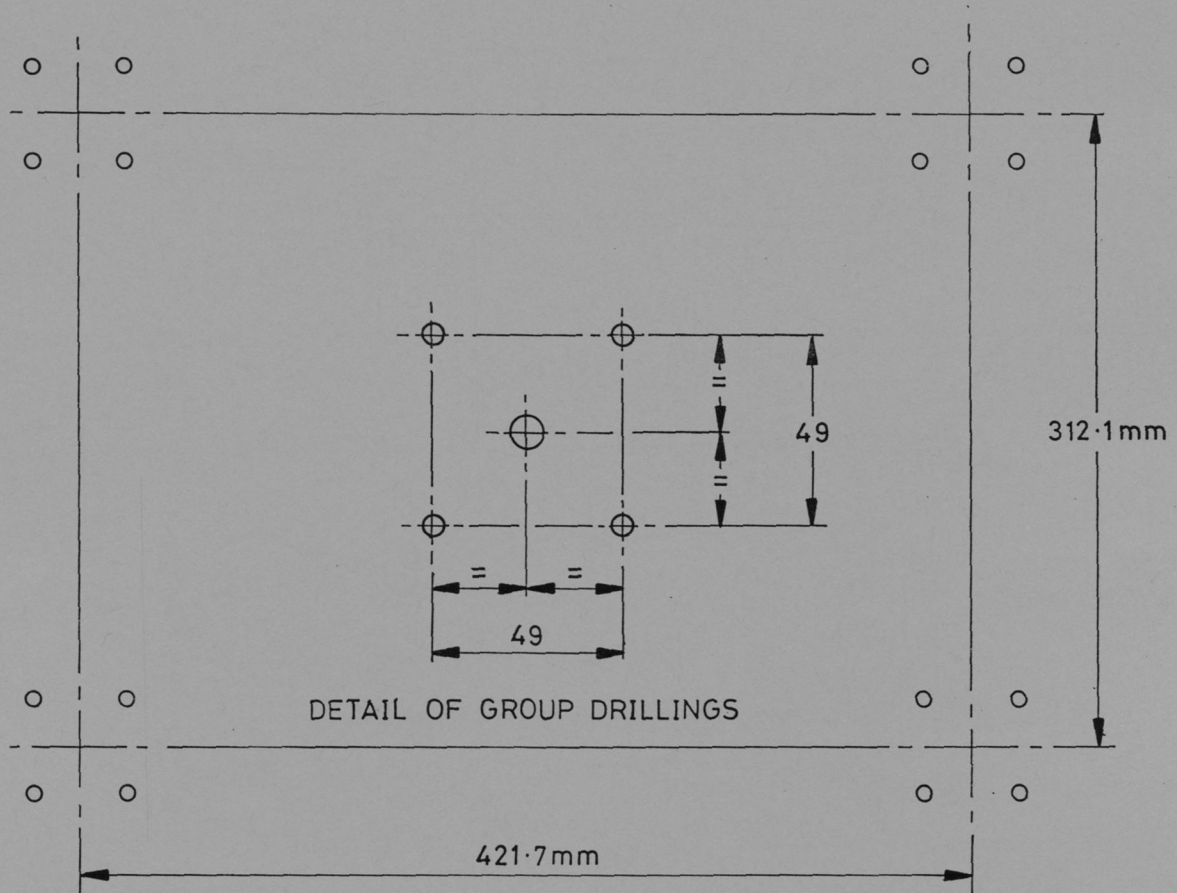

Figure 2.2
Drilling details for fixing Anti-Vibration Mountings



2.2 EXTERNAL CONNECTIONS

All external connections are made at the rear of the receiver with the exception of the headphone jack on the front panel.

2.2.1 A.C. Mains Input Connector

The A.C. MAINS INPUT socket accepts a 40-60Hz mains supply within the range specified using a standard I.E.C. connector.

WARNING



The A. C. mains supply MUST be completely disconnected from the receiver whilst the rear panel supply voltage selector is adjusted to suit the local supply conditions.

If a moulded plug and lead is used, a connector to suit the local supply arrangements can be fitted to the free end, observing the colour code which is as follows:-

LINE	-	BROWN
NEUTRAL	-	BLUE
EARTH	-	GREEN/YELLOW

The following additional information is issued in accordance with British Standard BS415 and concerns mains supply connections for the U.K.

'If the colours of the wires in the mains lead of this apparatus do not correspond with the coloured markings identifying the terminals in your mains connector (or plug), proceed as follows:-

1. The GREEN/YELLOW wire must be connected to the plug terminal marked "E" or " \perp " or coloured GREEN or GREEN/YELLOW.
2. The BLUE wire must be connected to the plug terminal marked "N" or coloured either BLUE or BLACK.
3. The BROWN wire must be connected to the plug terminal marked "L" or coloured either BROWN or RED.
4. If a 13A (BS1363) Fused Plug is used for connection to the supply output, the plug MUST be protected by a 3A FUSE. If another type of plug is used, a fuse of the appropriate rating must be fitted either in the plug, or the adaptor, OR AT THE DISTRIBUTION BOARD.'

2.2.2 D.C. Supply Connector

The receiver may be powered from an external DC supply of +19V to +31V dc (negative ground). Connections are shown in Figure 2.3

An Earth Terminal is provided to allow the chassis of the receiver to be bonded directly to adjacent metalwork.

Figure 2.3
D.C. Supply connector

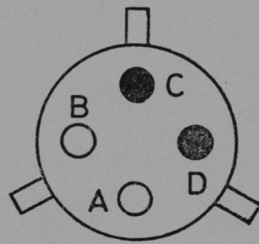

view into 4 way
male connector

D.C. Supply Connector

Pin	Description
A	Ground (0V).
B	+19V to +32V.
C	Not Used.
D	Not Used.

Connector 4Way PLUG Ref. (1) PL2

--oOo--

2.2.3 Ancillaries Connector

The pin connections and fundamental characteristics are given in Figure 2.4.

Figure 2.4
ANCILLARIES Connector

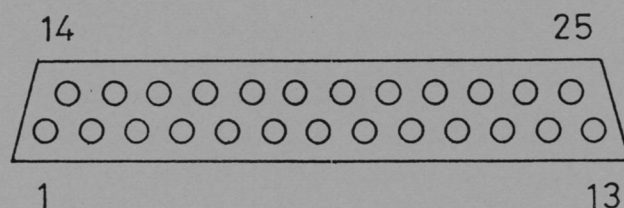

view into 25 way
female connector

ANCILLARIES Connector

Pin	Description
1	AF O/P (8 ohms).
2	External reset input (Active LOW).
3	Sidetone input - 2VRMS input to give 200mW AF output (>10k input resistance).
4	Diversity AGC - May be paralalled with a number of receivers.
5	15V dc output at 50mA for external equipment.
6	600R line O/P)
7	600R line O/P CT) preset at 10dBm
8	600R line O/P) by front panel
) control (11)RV2.
9	RF Mute (ground to mute). Pulled down 'R' to mute from +15V through 10k.
10	RF Mute)+12V to +30V
)maximum to mute
11	IF Mute)or desense.
12	AF Mute (ground to mute internal speaker). Pulled down 'R' to mute from +15V through 10k.

Figure 2.4 (continued)

- 13 Mute indicator. (Open collector transistor output, 50mA maximum current, 30V maximum voltage, transistor 'on' when signal not present).
- 14 Earth for 1 (unmuted).
- 15 Earth for 1 (muted via headphone jack on front panel).
- 16 Earth for 3.
- 17 Earth for 4.
- 18 Earth for 5.
- 19 Earth for 6.
- 20 Earth for 7.
- 21 Earth for 8.
- 22 Earth for 9 or 10.
- 23 Carrier operated relay pole.
- 24 Carrier operated relay contact - Signal present.
- 25 Carrier operated relay contact - Signal absent.

Connector 25Way 'D' SOCKET Ref. (1) SK4

--oOo--

2.2.4 Remote Control Connections

Connections to the REMOTE connector are detailed in Figure 2.5. The 5V CMOS/TTL level serial data inputs and outputs (and frequency data output if necessary) can be converted to RS232C (V24/V28) levels or RS422A (V11) levels using a 1760 or 1761 Remote Interface Adaptor (R.I.A.) respectively. The interconnections required are shown in the 1760/1761 manuals.

Figure 2.5
REMOTE Connector

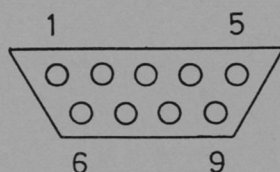

view into 9 way
male connector

REMOTE Connector

Pin	Description
1	FSK Data Output RS232C on suffix /K receivers.
2	Serial Frequency Data Output at 5V CMOS/TTL level (will drive up to 15 LS TTL loads or equivalent). 2400 Baud asynchronous data, 1 start bit and 2 stop bits (including parity). Data always indicates frequency to which receiver is tuned and thus can be used to control ancillary equipment also requiring this information. i.e. External Preselector and Panoramic Display. The complete frequency output is totally updated at least each second at a resolution of 100Hz. The contents of each data byte indicates the resolution of the digit and it's value in BCD form. An even parity bit is supplied for error checking, see Table 2.3.
3	Hold scan/sweep input. Pull to ground through less than 10k to halt the scan/sweep process. Internally pulled up to 5V via 10k. Do not exceed 5V on this input under any circumstances.
4	Serial Data Output at 5V CMOS/TTL level (will drive up to 15 LS TTL loads or equivalent).

Figure 2.5 (continued)

- 5 Serial Data Input. 5V CMOS input internally pulled up to 5V via 10k. If driven by TTL use additional 2k7 pull up to 5V on TTL driver. Do not exceed 5V on this input under any circumstances.
- 6 Analogue ground for pin 7.
- 7 Analogue Meter output corresponding to front panel METER reading and giving approximately 1V output at minimum deflection and 3.5V at maximum. Output impedance approximately 1k to 5k.
- 8 15V dc output at 50mA maximum for external equipment such as 1760/1 Remote Interface Adaptor.
- 9 Digital ground for pins 1 to 5 and 8.

N.B. All connections must be adequately screened.

Connector 9Way 'D' PLUG Ref. (1) PL1

--oOo--

Table 2.3
Serial Frequency Data Output

Note D0 is sent first

D7	D6	D5	Digit	D4	D3	D2	D1	D0
0	0	0	10MHz	Setting of digit				Odd Parity
0	0	1	1MHz	specified by D5 to				bit
0	1	0	100kHz	D7. Range is 0-9				
0	1	1	10kHz	except for 10MHz				
1	0	0	1kHz	which is 0-2				
1	0	1	100Hz					

2.2.5 Antenna Switch

A possible choice of up to four (0-3) external aerials may be selected with the Antenna Switch operated from the receiver front panel, see Section 3.2.8. An External Antenna Selector may be powered and driven from the receiver via 1SK3, see Figure 2.6.

Figure 2.6
ANTENNA SWITCH CONNECTOR

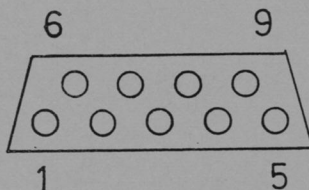

view into 9 way
female connector

ANTENNA SWITCH Connector

Pin	Description
1	Select Antenna 0 (active HIGH). Output drives 2TTL or 8LSTTL loads.
2	Select Antenna 2 (active HIGH). Output drives 2TTL or 8LSTTL loads.
3	Ground.
4	+12V at 300mA peak for antenna switch motor.
5	Ground for 4.
6	Select Antenna 1 (active HIGH). Output drives 2TTL or 8LSTTL loads.
7	Select Antenna 3 (active HIGH). Output drives 2TTL or 8LSTTL loads.
8	+5V at 50mA for antenna switch logic supply.
9	Ground for 8.

Connector 9Way 'D' SOCKET Ref. (1) SK3

--oOo--

2.2.6 Aerial Input Connector

Aerial input connection is by 50 ohm BNC socket (1SK1).

2.2.7 IF Output (High Level)

IF output connection is by 50 ohm BNC connector (1SK6).
IF output is 20mV/50 ohms pd under full AGC conditions.

2.2.8 IF Output (Low Level) (Suffix /P receivers)

IF output connection is by 50 ohm BNC connector (1SK2).
IF output is +10dB above signal input level.

2.2.9 External Standard Input (Suffix /S receivers)

External Standard Input connection is by 50 ohm BNC connector (1SK5). An input level of greater than 500mV ppd at either 1MHz or 5MHz will lock the receiver to the external standard. In order to lock to 1MHz link pins 5 and 6 on the External Standard Board ref 17. In order to lock to 5MHz open circuit pins 5 and 6 on the External Standard Board ref 17. The External Standard Board is located as part of the Synthesiser Board ref 8. The front panel LED 'External Standard' shows that the correct input level only is present on 1SK5. Receiver 'Out of Lock' is shown by the BITE LED flashing when not in BITE Mode - see Section 3.3.1.

2.3 SETTING UP PROCEDURES

2.3.1 A.C. Supply

WARNING



The A. C. mains supply MUST be completely disconnected from the receiver whilst the mains voltage selector, located on the back panel, is adjusted for the local supply.

2.3.2 Fuses

A.C. FUSE (1)FS1 : 1A(T) anti-surge 20mm cartridge fuse in series with the LINE input.

D.C. FUSES (1)FS2, (1)FS3 : 3A 20mm cartridge fuse in series with the mains transformer secondary.

D.C. FUSE (1)FS4 : 6.3A 20mm cartridge fuse in series with the external +ve DC supply input.

All fuses are accessible on the rear panel.

2.3.3 Preset Option Selector

An internally fitted dual-in-line (DIL) switch selects certain remote control options, whether the serial frequency data output is enabled and whether the keyboard sounder is enabled.

The switch is positioned at the top left hand behind the receiver front panel. To access, remove the receiver from it's cabinet or rack and remove the top dust cover (if fitted). The switch is shown in Figure 2.7. The individual switches are set as required and are read by the microcomputer during Power-On-Reset and the selected options stored. Thus every time a switch is set to a new option, the receiver must be reset by interrupting the power supply or by applying a low to the external Reset line (pin 2 of the rear panel ANCILLARIES connector).

Figure 2.7
PRESET OPTION SELECTOR SWITCH

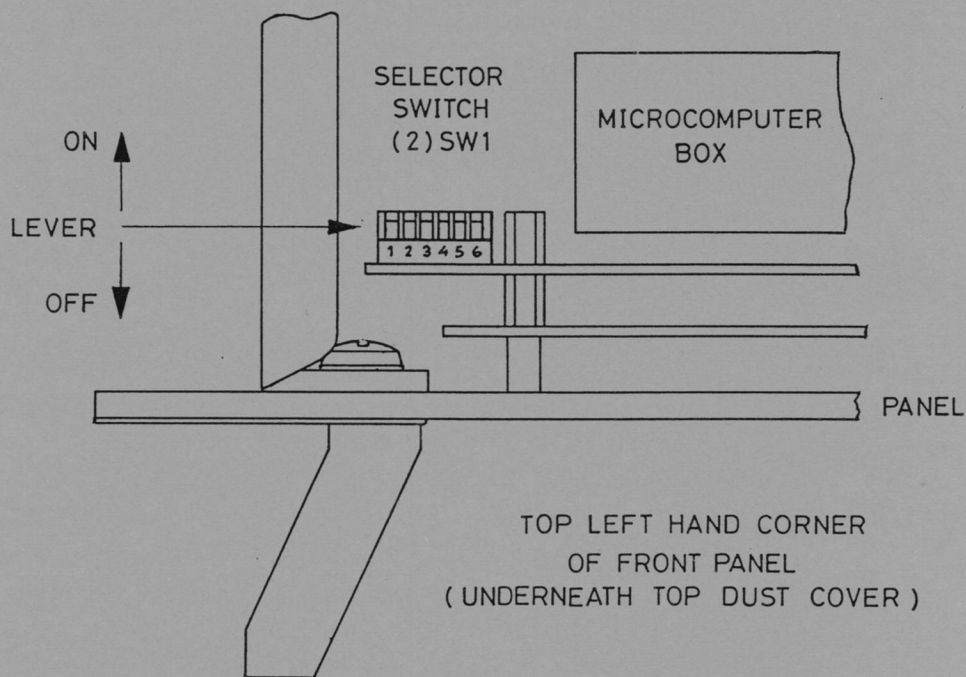

view onto top left hand corner of front panel
(underneath top dust cover)

Switch	Function
1	ON position enables keyboard sounder.
2	ON position for 250mS byte timeout. OFF position for 2Sec byte timeout.
3	ON position for 1200 Baud remote control. OFF position for 300 Baud remote control.
4	ON position for Local priority remote control. OFF position for Remote priority remote control.
5	ON position enables 2400 Baud serial frequency data output. OFF position - no output.
6	ON position to enable WIDEBAND switch operation. OFF position to disable WIDEBAND switch operation.

The selected options can be monitored using BITE test number 98. The number of each switch set at ON is displayed.

2.3.4 Aerial Voltage Overload Protection

A choice of aerial protection techniques is available depending upon the state of link pins 1 and 2 on the RF/1st IF board ref 7 as follows :-

1) Link pins 1 and 2 disconnected : Aerial protection afforded by shunt diodes and a gas surge arrester. The shunt diodes provide continuous protection for an input signal of 30V rms emf / 50ohms. High voltages are protected against by the 90V gas surge arrester.

2) Link pins 1 and 2 connected : Aerial protection afforded by 1) and a voltage level detector switch which disconnects the aerial input and short circuits the receiver input. This system operates when the aerial input voltage is of the order of 1V - 2V rms emf / 50ohms with 6dB of hysteresis - providing protection of 50V rms emf / 50ohms. The protection switch operates between 25mS - 50mS after signal onset.

SECTION THREE : OPERATION

This section starts with a description of each front panel control. A quick reference guide is given in Table 3.1. Signal Reception, BITE (Built-In-Test-Equipment), Channelised Operation, Scanning and Sweeping are then detailed separately. Each of these separate sections should be read and understood before proceeding to the next. Note however, that basic use of the receiver does not require all of them to be studied. A number of examples are given to show typical useage.

3.1 CONTROLS

A front view of the receiver, showing all the controls, is given on BP2092 bound at the rear of the manual. Certain controls have different uses depending on the current receiver operating mode. If a control has no function in the current mode, then a distinctive warble tone is sounded if the keyboard sounder is enabled. This and various other options are detailed in Section 2.3.3.

3.1.1 Receiver Operating Mode Keys

These keys are grouped with the numerical entry keys on the left-hand side of the main control knob and have red LED indicators. They control the mode of operation of the receiver control system (as opposed to the mode of signal reception and demodulation). The operating mode selected also affects the action of the other front panel controls.

RECALL

This mode initially copies the contents of the channel memory being received into the free tuning channel 00. The receiver is tuned to this channel and the channel data controls are enabled to allow the received frequency, selectivity etc. to be adjusted. Selection of this mode immediately allows the 1650 to be used as a conventional free-tuning receiver, starting from the actual frequency etc. being received (no matter what previous operating mode was in use). RECALL mode should therefore be selected if simple control without all the other operating facilities is required or if instant display and control of a received signal is required.

CHANNEL

When in this mode, the contents of the channel memories can be interrogated (without breaking into the signal being received). The number of the channel to be viewed can be entered using the numerical keys and can be incremented or decremented using the main control knob. The CHANNEL 'decimal points' will flash if the channel being displayed is not the channel being received. Note that CHANNEL mode should be selected before other channel operations to ensure that channel contents are viewed before they are used or modified (this has to be done before STORE or START CHANNEL). The first channel displayed when selecting CHANNEL mode directly after RECALL or TUNE mode, will be the channel to which the receiver was originally tuned, or which was being displayed, respectively. When in CHANNEL mode, the signal reception settings (frequency etc.) cannot be directly altered by the channel data keys.

RECEIVE

Tunes the receiver to the channel selected in CHANNEL mode. The signal reception settings will remain as initially displayed and cannot be altered by the channel data keys. CHANNEL and TUNE modes can then be used to interrogate, load or modify memories (apart from the selected RECEIVE channel memory) without breaking into the signal being received. This mode is generally used to tune the receiver, for long periods, to specific frequencies, signals etc. which require no further receiver adjustment.

TUNE

This mode initially copies the contents of the channel memory being displayed into the free tuning channel 00. The channel data controls are enabled to allow the contents to be altered so that new settings can be loaded back into the original, or a different memory, using CHANNEL and STORE modes. The settings do not have to be altered whilst in channel 00 thus allowing a memories contents to be duplicated in another memory. This mode is used to load or alter channel memories whilst the receiver stays tuned to the channel selected in RECEIVE mode (without breaking into the received signal as long as its channel contents are not altered).

STORE

This copies the contents of the free tuning channel 00 into the memory selected in CHANNEL mode. CHANNEL mode must be selected before STORE is used. The operating mode will automatically return to CHANNEL after the store operation is completed. STORE is used to copy the receivers actual signal reception settings into a chosen memory or to transfer new or modified settings, entered during TUNE mode, to a chosen memory. Note that the contents of channel memories 01 to 99 can only be altered by use of the STORE mode (ie. are not free-tuning). Note also, that if a channel memory, which is set to be scanned, is used as the origin for data in channel 00, use of STORE will also put the channel to which the data is then moved, into the scan sequence.

DWELL

In this mode, the FREQUENCY kHz display indicates the scan/sweep dwell period (left-hand side of display, 0.0 to 9.9 secs.) and the scan/sweep hang period (right-hand side, 0 to 9 secs.) Dwell and hang times are entered together using the numerical keys. Turning the main control knob steps through the channel numbers of those channels set to be scanned (the SCAN CHANNEL LED will flash as well). If no channels are set to be scanned, and the keyboard sounder is enabled, the 'invalid' tone will sound. In this mode channels can be removed from the scan sequence by pressing SCAN CHANNEL whilst they are being displayed (the SCAN CHANNEL LED will stop flashing to indicate that they have been removed).

SCAN
CHANNEL

Use of this key whilst in CHANNEL mode toggles the displayed channel in or out of the scan sequence. The associated LED will flash to indicate when the displayed channel is in the scan sequence. In DWELL mode it is used to remove channels from the scan sequence. Note the free tuning channel 00 cannot be in the scan sequence.

SCAN

In this mode the receiver continually scans the selected channel memories in order of channel number, staying on each channel for the selected dwell period (as long as at least two channels are set to

be scanned). If MUTE is also selected, and a signal above the mute threshold is detected, the receiver will stay on that channel and remain there for the selected hang period after the signal ceases. Note that the receiver can be made to stay on a particular channel by selecting RECEIVE mode or can be made to operate as a free tuning receiver, starting on a particular channels settings, by selecting RECALL mode. The scan sequence can be simultaneously controlled using the front panel main control knob (channel data settings cannot be directly adjusted whilst scanning). If a dwell of 0.0 has been selected, the knob has sole control of the scan sequence and thus provides 'tuning by channel'.

START
CHANNEL

Use of this key whilst in CHANNEL mode selects the displayed channel to be the start channel for the frequency sweep sequence. The associated LED flashes to indicate that the displayed channel is the selected start channel. There can only be one start channel selected at any time, therefore when a new one is selected, it replaces the original one. Note the free tuning channel 00 cannot be the sweep start channel.

RATE

In this mode, the FREQUENCY kHz display shows the selected step (00.00 to 99.99kHz) for both main control knob tuning and automatic sweep tuning. A new rate can be entered using the numerical keys. Note that 00.00 kHz indicates automatic variable rate for knob tuning and is invalid for automatic sweep tuning. The channel display indicates the selected sweep start channel.

SWEEP

In this mode the receiver continually sweeps or tunes between the frequency stored in the selected start channel and that stored in the next highest numbered channel (for example 45 and 46). Other signal reception settings remain as stored in the lower numbered channel. The sweep can be in ascending or descending frequency and proceeds in the step set in RATE mode (note 00.00 kHz invalid). The receiver remains on each step for the

selected dwell period. If the step is 5KHz or greater, and MUTE is selected, the receiver will halt on a step which contains a signal above the threshold and remain there for the selected hang period after the signal ceases. The sweep sequence can be simultaneously controlled using the main control knob (channel data settings cannot be directly adjusted whilst sweeping). If a dwell of 0.0 has been selected, the knob has sole control of the sweep sequence and thus provides tuning between defined limits.

BITE

When in this mode, the full BITE facilities are available. The required BITE test number (00 to 99) can be entered using the numeric keys and can be incremented or decremented using the main control knob. The FREQUENCY kHz display shows the selected BITE number (left-hand side) and the result of the test (PASS or FAIL on the right-hand side). Unused tests are shown as SPARE. Test 98 indicates the internal option settings (see section 2.3.3), test 99 displays the version of software used in the receiver (as Operating System X.X). Allow adequate time for tests to settle, especially when testing the narrowband pre-selector (suffix /A receivers, tests 57-81 inc.). When the receiver is not in BITE mode, the BITE LED will flash if the BITE circuitry detects a potential fault at the point at which the receiver is currently operating. Intermittent flashes of the LED when the receiver is being rapidly tuned can occur and do not necessarily indicate a fault.

3.1.2 Numerical Keys

These keys are grouped with the receiver operating mode keys to the left of the main control knob. Numerical information is displayed in the CHANNEL and FREQUENCY kHz displays, the latter also being used to display other information apart from frequency, depending on the current receiver operating mode.

0 to 9 These are used to enter numerical data, the content of which depends on the receiver operating mode. The tuned frequency is entered in RECALL or TUNE modes. The channel number in CHANNEL mode.

The dwell and hang times in DWELL mode.
The tuning rate in RATE mode and the BITE
test number in BITE mode.

3.1.3 Main (Central) Control Knob

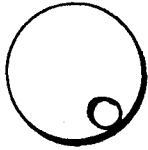

This is used to increment or decrement data depending on the receiver operating mode and the state of the BFO and AUXILLARY ANTENNA keys. In RECALL or TUNE modes the knob controls the frequency, unless BFO or AUXILLARY ANTENNA is selected. Then the knob selects the BFO offset or the required auxilliary antenna respectively. When used to control the frequency, the knob can be used to 'fill-in' trailing zeros of a numerical key frequency entry, this also enabling an incorrect entry to be quickly finished so that it can be restarted. In CHANNEL mode the knob alters the displayed channel number. In DWELL mode it shows the numbers of channels which have been set to be scanned. In SCAN or SWEEP modes it alters the scan or sweep position and in BITE mode it steps through the BITE tests.

3.1.4 Channel Data Keys

These are grouped just below the CHANNEL and FREQUENCY kHz display, the associated LEDS being orange/red. These keys, along with the numeric keys and the main control knob are used to directly alter the contents of the free tuning channel 00 in RECALL and TUNE modes only, all such settings being capable of being independently stored in channel memories 01 to 99 using STORE mode. Note that on all modes but RECALL and TUNE, the channel data keys are invalid and the settings described cannot be altered at will.

MODE

This key steps through the signal demodulation settings AM, SSB, CW, or FM. AM provides envelope detection, SSB provides product demodulation with a fixed detector injection frequency, CW provides product demodulation with variable injection from the BFO and also switches in an audio peaking filter centralised at about 1kHz. FM also provides this last choice but without the audio filter (for FSK demodulation) unless the receiver is

fitted with an NBFM demodulator (suffix /N receivers) in which case, that demodulator is selected.

RF SENS

This key steps through the RF signal input attenuator settings of MAX (no attenuation), -10dB, -20dB and MIN (an unspecified attenuation level of at least 40-50dB).

AGC

This key steps through the AGC choices of audio AGC, conventional AGC with slow or fast decay and AGC off (manual IF gain). In the last case, the IF GAIN/MUTE LEVEL control sets the receiver gain level (this being indicated by the front panel meter in the RF setting). Otherwise, when AGC is on, this level control determines the signal threshold level used by the mute, scan or sweep halt and carrier operated relay functions (the set level is indicated by the front panel meter in the COR setting). Note that the audio mute and scan/sweep halt threshold level on NBFM only (suffix /N receivers), can be noise determined if required, by setting internal links. The level in this case is set internally.

**I.F.
BANDWIDTH
kHz**

This key steps through the available IF selectivity settings of between 0.3 and 16kHz. Note that this key also determines whether USB or LSB demodulation is provided in SSB mode.

3.1.5 Miscellaneous Controls and Displays

The remaining controls and displays can generally be used in any receiver control mode although in some they may not provide a useful action. They are subdivided into three groups. The main group is on the immediate right-hand side of the main control knob, the associated LEDs being green. The second group consists of rotary controls beneath the loudspeaker. The final group is immediately to the right of the FREQUENCY kHz display, the associated LEDs being yellow.

METER

This key steps through the front panel meter indication settings. CZ

(centre-zero) is only used for tuning purposes if the NBFM option is fitted (suffix /N receivers) or if the internal FSK demodulator is fitted (suffix /K receivers). AF is used to indicate the audio line output power level (calibrated at 10mW into 600 Ohm). RF indicates the received signal level (approximately 0dBuV to +50dBuV emf input signal corresponds to zero to full meter deflection), unless AGC off is selected, in which case it indicates the setting of the IF GAIN/MUTE LEVEL control. COR indicates the setting of this level control and thus indicates the threshold level for the mute, carrier operated relay etc., when one of the AGC on positions is selected. The calibration of the meter in RF and COR is the same and thus the COR or threshold level should be set so that the meter reading set on COR is the same as the meter reading obtained on RF by signals just at the required threshold level.

BFO

This determines if the main control knob is to be used to set the BFO offset (0.0 to + or - 3.9 kHz). This mode can be exited by pressing BFO again (frequency display) or by selecting AUXILLARY ANTENNA.

WIDEBAND

This is used to bypass the narrowband preselector when fitted (suffix /A receivers). When the preselector is not fitted, the internal option switch should be used to disable this key and show wideband permanently on (see section 2.3.3)

**LOUD
SPEAKER**

This key switches on or off the front panel monitor loudspeaker.

REMOTE

This key is used to disable the rest of the front panel keyboard when local priority remote control is internally selected. The key is invalid when remote priority remote control is internally selected. In this later case the associated LED indicates that the remote controller has enabled local control

inputs (LED off) or has 'locked' them out (LED on). Note that whenever the REMOTE LED is on, the remote controller has control of the manual IF gain or mute threshold level. See section 2.3.3 for more information.

EXTERNAL
DC SUPPLY



This is an indicator only that shows when an external DC supply has automatically taken over when no suitable mains supply is present.

MUTE

This key enables the audio muting circuit and the scan/sweep halt threshold detector (when using 5kHz steps or greater on sweep). Note that the carrier operated relay operates independently of this key.

AUXILLARY
ANTENNA

This determines if the main control knob is to be used to select the auxillary antenna (0 to 3). This mode can be exited by pressing AUXILLARY ANTENNA again (frequency display) or by selecting BFO.

EXTERNAL
STANDARD



This is an indicator only which shows when an external frequency standard input of adequate level is present (suffix /S receivers). If not in BITE mode the BITE LED will then flash if the receiver is not locked to the external standard.

ON/STBY

This key is used to disable the rest of the receiver keyboard and switch off the whole display apart from the associated OVEN LED.

OVEN



This LED indicates that power is applied. Note however that its brightness is controlled by the DISPLAY INTENSITY control and it may be dimmed to extinction.

SIGNAL



This LED indicates that a signal is present above the set threshold level. Note that on NBFM (suffix /N receivers) when noise threshold is internally selected, it indicates a signal is present above the noise threshold.

IF GAIN
/ MUTE
LEVEL



This knob controls the level of IF gain when AGC off is selected (displayed with the meter set to RF). When audio, slow or fast AGC is selected this knob sets the COR, audio mute and scan/sweep halt threshold levels (displayed with the meter set to COR). Note that when noise derived mute has been selected internally for NBFM (suffix /N receivers), this control has no effect on the NBFM audio mute and scan/sweep hold threshold. It does however still set the NBFM carrier operated relay threshold.

AF GAIN



This knob sets the output level of the front panel monitor loudspeaker. It also sets the output level from the front panel PHONES jack and from the rear panel high level audio output connector.

LINE
LEVEL



This preset control sets the output level from the rear panel audio line output connector. This level is displayed with the meter set to AF.

DISPLAY
INTENSITY



This knob sets the intensity of the whole front panel display. Note that the display may be dimmed to extinction, thus in general use, care should be taken that this control is not left fully anti-clockwise.

PHONES



This is a standard mono audio connector jack for headphones etc. Alternative rear panel high level audio output connections allow optional muting of that output when a jackplug is inserted into the PHONES connector. The front panel monitor loudspeaker remains unmuted and, if necessary, can be switched off separately from the keyboard.

Table 3.1
Receiver Operating Modes

CONTROL MODE	DISPLAY	MAIN KNOB	NUMERICAL KEYS	CHANNEL DATA KEYS	BASIC OPERATION
RECALL	Conventional Receiver Display	Changes Frequency or BFO	Load Frequency Only	Enter Channel Data	Receiver operates conventionally starting at channel being received
TUNE	Conventional Receiver Display	Changes Frequency or BFO	Load Frequency Only	Enter Channel Data	ditto-but starting at channel being displayed
STORE	Temp. Mode Only	Invalid	Invalid	Invalid	Data copied from free tuning channel 00 into channel displayed
RECEIVE	Conventional Receiver Display	Invalid	Invalid	Invalid	Receive on channel displayed (data entry inhibited)
CHANNEL	Conventional Receiver Display	Alters Channel Number	Enter Channel Number	Invalid	Channel selected for 'TUNE', 'RECEIVE', 'SCAN CHAN', 'START CHAN' or 'STORE' modes
SCAN CHANNEL	Temp. Mode Only	Invalid	Invalid	Invalid	Channel displayed toggled in or out of scan sequence
DWELL	Dwell, Hang and Scan Channels	Displays Scan Chan. Nos	Enter Dwell/ Hang Periods (Secs)	Invalid	Display / entry of scan / sweep parameters
SCAN	Conventional Receiver Display	Alters Scan Position	Invalid	Invalid	Scans each channel in scan sequence staying on each for 'DWELL'
START CHANNEL	Temp. Mode Only	Invalid	Invalid	Invalid	Channel displayed set as sweep start channel
RATE	Dwell, Hang and Scan Channels	Invalid	Enter Tuning Rate (kHz)	Invalid	Display / entry of tuning rate / sweep start channel
SWEEP	Conventional Receiver Display	Alters Sweep Position	Invalid	Invalid	Sweeps from frequency in 'START' to that in next channel
BITE	Bite Test No. and Report	Alters Bite Test Number	Enter Bite Test Number	Invalid	BITE tests performed

3.2 SIGNAL RECEPTION

3.2.1 Switching On



Ensure that the rear panel voltage selector is set for the local mains power supply, turn the <DISPLAY INTENSITY> control fully clockwise and apply mains power.

All display LEDs (except for the meter) will briefly illuminate and then rESEt will be displayed. rESEt indicates power-on-reset and is accompanied by three tones from the keyboard sounder. Finally the display will clear to one of the control mode formats.

If only the OVEN LED and possibly the meter LEDs are on, the receiver is in standby. In this case press <ON/ST BY> to use the receiver. In standby, the receiver display (apart from the OVEN and meter LEDs) is turned off and the main outputs are muted. However, the oven controlling the internal frequency standard temperature is left on. When the receiver is initially in use, standby can be selected by pressing <ON/ ST BY>.

If the REMOTE LED is on, and the receiver is not in a remote control system, press <REMOTE> to obtain local control. If this or any other keyboard operation is not possible, the receiver may be internally set for remote control priority. This will be shown by pressing <BITE>, <9>, <8>. The number 4 should be displayed (local priority selected). If it is not, it can be set internally, see section 2.3.3.

If the BITE LED flashes, it may indicate a potential fault at the current receiver settings. However at switch-on, at certain tuned frequencies, the LED may flash for one or two minutes as the internal standard warms up to its operating temperature. On suffix /S receivers, the BITE LED will also flash if an external frequency standard is selected which is of correct level but to which the receiver will not lock. The EXTERNAL STANDARD LED will be on to indicate that the level is correct. If it is, press <BITE>, <0>, <4> to determine if it is locked (should display PASS). Note that the external standard cannot be selected at will from the front panel. Other BITE warnings should be investigated using the BITE procedure, see section 3.3.

If use of the front panel monitor loudspeaker is required, ensure that the LOUDSPEAKER LED is on. If it is not, press <LOUDSPEAKER>. If headphones or an external loudspeaker is being used, the front panel loudspeaker should normally be switched off. If the

rear panel audio line output is being used, press <METER> repeatedly to select AF and display the output level (calibrated at 10mW into 600 Ohm).

If an internal narrowband pre-selector is fitted (suffix /A receivers), press <WIDEBAND> to select the preselector (LED off) or bypass the preselector (LED on) as required.

If the MUTE LED is on, press <MUTE> to prevent loss of audio whilst performing initial tuning.

Note that if the EXTERNAL DC LED is on, it indicates that the receiver has automatically switched to a DC power supply, the mains power supply being insufficient or absent. This is an indicator only, the source of power cannot be selected at will at the front panel.

If use of the equipment as a conventional free-tuning receiver is required, and the RECALL LED is not on, press <RECALL>. Use involving the stored channels is described in sections 3.4, 3.5 and 3.6.

3.2.2 Setting the Tuned Frequency

This can only be done directly from the front panel into the free tuning channel 00 with RECALL or TUNE mode selected.

If the BFO LED is on, press <BFO> to obtain the tuned frequency display. Similarly, if the AUXILLARY ANTENNA LED is on, press <AUXILLARY ANTENNA>.

The FREQUENCY kHz display will show the tuned frequency. A blank display will indicate that a valid frequency is not loaded. Use of the numeric keys then enters the frequency, always starting with the most significant digit, 10MHz. For frequencies lower than 10MHz, all the leading zeros must be entered into the display, digits remaining to be entered shown as bars, except for the 1Hz digit (always 0 during a numeric key entry). The bars are gradually replaced by the numbers entered.

If the keyboard sounder is enabled, a longer tone sounds as the last (10Hz) digit is entered. Turning the main control knob fills in trailing zeros or thus helps to quickly restart an incorrect entry. The 10MHz digit is limited to a maximum of 2 (allowing entry of frequencies up to 29999.990 kHz). The lowest frequency which can be entered is 10.000kHz. Entry of frequencies below that, for example, all 0s, clears the display.

Example 3.1
To Tune to 143.780kHz

Press <0>, <0>, <1>, <4>, <3>, <7>, <8>.

The last, 1Hz, digit is automatically entered as zero when the first , 10MHz, digit is entered.

Example 3.2
To Tune to 21000.560 kHz

Press <2>, <1>, <0>, <0>, <0>, <5>, <6>.

Example 3.3
To Tune to 25000.000kHz

Press <2>, <5> and turn the main control knob slightly.

This enables rapid entry of any frequency with a large number of trailing zeros.

When a frequency is displayed in RECALL or TUNE modes, it can be adjusted using the main control knob. The rate of tuning is set as follows.

Press <RATE>. The frequency display is replaced by the tuning step which is in the range 00.00 to 99.99kHz (10Hz increments). This step can be altered using the numeric keys, with the digits entering the display from the left. In general it is best to enter all four digits, including any leading or trailing zeros.

Example 3.4
To Select 1KHz Steps

Press <RATE>, <0>, <1>, <0>, <0>.

The rate gives the tuning steps starting from the initial frequency shown or entered. Many bands are split up into specific channels (eg. 9kHz on some broadcast bands) and are thus best searched using the appropriate step. Note that the starting frequency need not be a whole multiple of the selected rate, thus allowing stepping through frequency channels which are offset from a multiple of the channel spacing. The smaller steps allow fine tuning as required. However, for general use, a rate of 00.00kHz can be selected which provides automatic variable rate tuning with the step then increasing from 5Hz upwards as the speed, at which the main control knob is turned, is increased. Note that this is the only way that 5Hz steps can be made.

For use as a conventional free-tuning receiver press <RECALL> after the required rate has been selected.

3.2.3 Signal Mode Settings

The <MODE> key is used to step through the reception mode options of AM, SSB, CW and FM. the reception bandwidth is set by the <I.F. BANDWIDTH kHz> key (0.3 to 16kHz). This key also determines if the USB or LSB is used for demodulation. When CW is selected the BFO can be used to determine the detected audio output frequencies. On CW a peaking audio filter is also selected, centred on about 1kHz. On FM the BFO is again used but without the peaking filter. This allows a wider audio output frequency range for FSK etc. However, if an NBFM module is fitted (suffix /N receivers), the FM mode is used for NBFM only (i.e. the BFO is not used).

On SSB, where the BFO is also not used, clarification of the signal is performed using the main control knob after using <RATE> to set a small step (00.01 to 00.10kHz) or the automatic variable rate (00.00kHz).

Example 3.5
AM Reception

Press <MODE> repeatedly to select AM.

Press <I.F. BANDWIDTH kHz> repeatedly to select usually 3kHz for amplitude modulated CW / radiotelephony or 8kHz for broadcast AM (for this, 16kHz will give a slightly wider audio frequency response).

Tune to the desired signal as described in section 3.2.2.

Example 3.6
USB or LSB reception

Press <MODE> repeatedly to select SSB.

Press <I.F. BANDWIDTH kHz> repeatedly to select USB 2.4kHz or LSB 2.4kHz as required.

Tune to the desired signal as described in section 3.2.2. Note that other bandwidths can be used, if required, but in that case the receiver must be offset from the nominal signal frequency, by about half the selected bandwidth, towards the desired sideband.

Example 3.7
CW Reception

Press <MODE> repeatedly to select CW.

Press <I.F. BANDWIDTH> repeatedly to select usually 0.3 or 1kHz.

Press <BFO> and set the BFO in the range 0.8 to 1.2 kHz (+ or -) using the main control knob. This setting equals the desired output tone in the range of the CW audio filter.

Press <BFO> again and tune to the desired signal as described in section 3.2.2.

Example 3.8
FM (FSK) Reception

Unless a NBFM module is fitted (suffix /N receivers), FSK can be received as follows.

Press <MODE> repeatedly to select FM.

Press <I.F. BANDWIDTH kHz> repeatedly to select usually 1kHz.

For FSK demodulators driven from the receiver's I.F. output (such as the Eddystone 1529) tune the receiver, as described in section 3.2.2, to obtain centre zero deflection (or equivalent) on the demodulator's tuning indicator.

For FSK demodulators driven from the receiver's audio output, press <BFO> and set the BFO to the nominal centre input frequency of the external demodulator. Then press <BFO> again and tune the receiver to obtain centre zero deflection (or equivalent) on the demodulator's tuning indicator. Note that the sign of the BFO offset (+ or -) determines the effective 'polarity' of the FSK signal. The polarity may be reversed or made correct if necessary, by setting the same BFO offset but with the other sign.

Example 3.9
FM (NBFM) Reception

When a NBFM module is fitted (suffix /N receivers), NBFM can be received as follows.

Press <MODE> repeatedly to select FM.

Press <I.F. BANDWIDTH kHz> repeatedly to select usually 16kHz.

Press <METER> repeatedly to obtain CZ (centre-zero).

Tune to the desired signal as described in section 3.2.2 noting that when the signal is correctly tuned, the meter reading should be approximately central. Note that it does not have to be exactly central.

3.2.4 Gain Control

Manual gain and three types of automatic gain control are available by pressing <AGC> repeatedly until the desired setting is obtained. When OFF is selected, gain is set by use of the <I.F. GAIN / MUTE LEVEL> control. The setting of this control can then be displayed on the meter by pressing <METER> repeatedly to select RF. The setting should approximately equal the reading that the received signal gives if FAST is temporarily selected.

AGC type is normally selected to suit the signal being received. AUDIO is generally used for SSB reception. SLOW can also be used for SSB as well as AM broadcast reception. Other signals generally require SLOW or FAST as best suits the prevailing reception conditions. When AGC on is selected, the <I.F. GAIN / MUTE LEVEL> control is used to set the audio mute, scan/sweep halt and COR (carrier operated relay) thresholds. One of the three AGC on settings, AUDIO, SLOW or FAST, must be selected for these functions to operate correctly.

In all cases the gain can be reduced by pressing <RF SENS> repeatedly to select -10dB, -20dB or MIN which gives at least 40-50dB R.F. attenuation. MAX gives zero R.F. attenuation.

3.2.5 Audio Mute Operation

Signal level derived audio muting is available on all reception modes. Note however, that when a NBFM module is fitted (suffix /N receivers) the NBFM audio mute only, can be level or noise derived, depending on the setting of internal links (section 2.3.5). In the noise case, the NBFM threshold is set internally and is not displayed on the meter.

Example 3.10 Selecting Audio Muting

If the MUTE LED is off, press <MUTE> to select audio muting and press <AGC> repeatedly to obtain AUDIO, SLOW or FAST as required for the signal type or prevailing conditions.

Press <METER> repeatedly to obtain COR and adjust the <I.F. GAIN / MUTE LEVEL> control to obtain a meter deflection equal to the meter deflection that would just be obtained by a signal at the desired threshold level with the

meter on RF. Note COR and RF meter calibrations are equivalent and equal to approximately 0dBuV to 50dBuV emf signals (for zero to full deflection).

When a signal above the threshold level is present, full audio output will be available and the SIGNAL LED on, otherwise, the audio output will be muted by about 20dB and the SIGNAL LED will be off. Note that the signal indicator has an open collector transistor output available on the rear panel so that external equipment can respond to signals above the audio mute threshold.

3.2.6 Carrier Operated Relay

This is similar to the audio muting facility except that it does not require MUTE to be selected (i.e. it is always operational). Again one of the AGC modes must be selected for correct operation, in which case, the COR operates when the signal exceeds the threshold level. The relay is a single pole changeover type (form 'C') with all contacts available on the rear panel. Thus the signal can be made to make or break a contact, as required, to operate external equipment. Note that the COR is always level dependent, even when noise muting is internally selected on NBFM (suffix /N receivers) and does not necessarily operate in concert with the SIGNAL LED and its rear panel open-collector transistor output.

Example 3.11 Setting COR level

Press <AGC> repeatedly to obtain AUDIO, SLOW or FAST as required for the signal type or prevailing conditions.

Press <METER> repeatedly to obtain COR and adjust the <I.F. GAIN / MUTE LEVEL> control to obtain a meter deflection equal to the meter deflection that would just be obtained by a signal at the desired threshold level with the meter on RF. Note COR and RF meter calibrations are equivalent and equal to

approximately 0dBuV to 50dBuV emf signals (for zero to full deflection).

When a signal above the threshold level is present, the carrier operated relay will switch over.

3.2.7 R.F. Selectivity

A narrowband, tracking R.F. preselector may be fitted (suffix /A receivers). This is in circuit when the WIDEBAND LED is off. In this case, if the preselector is not required, press <WIDEBAND>. In general the preselector should only be switched into circuit to remove interference from unwanted signals, since it slightly reduces the receiver's sensitivity and also lengthens the tuning time response if frequent and large changes are being made to the receiver's tune frequency. In receivers which do not have the preselector, an internal setting is made to make the key entry invalid (see section 2.3.3). A hard-wired link is also made to switch WIDEBAND permanently on.

3.2.8 Antenna Selection.

One of up to four remotely sited antennas (or other devices) can be selected from the receiver front panel. The control activates one of four rear panel TTL output control lines. To change or check the setting, if the AUXILLARY ANTENNA LED is not on, press <AUXILLARY ANTENNA>. The FREQUENCY kHz display will then show the selected device number which can be altered, if required, using the main control knob. Finally press <AUXILLARY ANTENNA> again to return to the frequency display.

3.3 BITE (Built-In-Test-Equipment)

3.3.1 Passive BITE

When the receiver is not in BITE mode, BITE continues to monitor certain receiver conditions and flashes the BITE LED if a potential fault is found. This is described as 'passive BITE'. When convenient, the source of the fault can be found by pressing <BITE> and stepping through the BITE tests using the main control knob. If the result of a particular test is required, its number can be directly entered using the numeric keys.

It should be noted that the BITE LED may flash for one to two minutes when the receiver is first switched on as the internal frequency standard warms up to its operating temperature. It may also intermittently flash if the receiver is rapidly tuned. Both of these conditions are normal and do not necessarily indicate a fault.

The tests performed in passive BITE are those which do not interfere with the reception of signals (tests 00 to 04 inclusive - see Table 3.2). They mainly indicate whether the synthesiser is in lock at the frequency to which the receiver is tuned. All passive tests will indicate PASS or FAIL as appropriate. Test 04 will also indicate SPARE. Table 3.2 gives a full description of all tests.

3.3.2 Active BITE

Comprehensive tests of the synthesiser and of signal paths through the receiver can also be performed. This involves switching the synthesiser over its whole range and injecting test signals from the inbuilt broadband noise generator and thus cannot be performed when the receiver is being used for signal reception. This is described as 'active BITE'. For this, BITE mode has to be selected (BITE LED permanently on) and the tests can then be stepped through using the main control knob or directly entered using the numeric keys.

Tests 98 and 99 are special tests which are used to display certain receiver status conditions. Test 98 indicates which of the internal option selector switches are set to ON (see section 2.3.3). If a switch is set to ON, its number appears in the display, otherwise it is absent. Test 99 indicates the receivers Operating System software issue number in the form O.S X.X. The information given by both these tests should be quoted if questions about operation arise.

Table 3.2
BITE Tests

BITE No.	Test	Notes
----------	------	-------

Test 00-04 inc. are the passive BITE tests which are made at the current receiver settings. Test 00 will appear as FAIL if any of the tests 01-04 fail. Test 04 will appear as SPARE if the external standard input is absent or is of insufficient level (the EXTERNAL STANDARD LED will also be off).

00	General alarm	as 01-04
01	+15.5v supply	
02	Synthesiser lock	
03	BFO lock	when in use
04	Ext Std. lock	when present

Tests 05 to 20 inc. are active BITE tests at the extreme ends of each individual synthesiser loop sub-range. The principal frequencies are those to which the receiver is tuned when at the extreme ends of the four main first loop ranges (LF, LF+1, HF-1 and HF). The two tests at each principal frequency are at the extreme ends of the single second loop range. Thus the tests will analyse if any particular first loop range has failed in total or just at one end and also if the second loop has failed just at one end (e.g all '+5Hz' tests fail). If either loop completely fails, all tests will fail.

05	10kHz lock	LF bottom
06	10kHz+5Hz lock	LF bottom
07	5790kHz lock	LF top
08	5790kHz+5Hz lock	LF top
09	6000kHz lock	LF+1 bottom
10	6000kHz+5Hz lock	LF+1 bottom
11	12790kHz lock	LF+1 top
12	12790kHz+5Hz lock	LF+1 top
13	13000kHz lock	HF-1 bottom
14	13000kHz+5Hz lock	HF-1 bottom
15	20790kHz lock	HF-1 top
16	20790kHz+5Hz lock	HF-1 top
17	21000kHz lock	HF bottom
18	21000kHz+5Hz lock	HF bottom
19	29998kHz lock	HF top
20	29998kHz+5Hz lock	HF top

Table 3.2 (continued)

BITE No.	Test	Notes
----------	------	-------

Tests 21 and 22 are active BITE tests at each end of the BFO synthesiser range.

21	-3.9kHz BFO lock	
22	+3.9kHz BFO lock	

Tests 23 to 36 inc. are overall signal path tests using the inbuilt noise generator to check each of the I.F. bandwidth determining filters/relays (or straight-through attenuator/relays on 16kHz). Each test is carried out in wideband mode (i.e. bypassing the narrowband preselector on suffix /A receivers) and at two different synthesiser settings to allow for a synthesiser fault at one of them. A faulty filter will be indicated by a fail at both frequencies. If all tests fail, a common signal path or more serious synthesiser fault is likely. The front panel meter indicates the test level and reads approximately half full scale when the level is correct. A fault producing approximately 20-30dB attenuation will produce a fail indication.

23	0.3kHz filter at 2MHz	10FL2 etc.
24	0.3kHz filter at 10MHz+5Hz	10FL2 etc.
25	1kHz filter at 2MHz	10FL4 etc.
26	1kHz filter at 10MHz+5Hz	10FL4 etc.
27	3kHz filter at 2MHz	10FL5 etc.
28	3kHz filter at 10MHz+5Hz	10FL5 etc.
29	LSB filter at 2MHz	10FL3 etc.
30	LSB filter at 10MHz+5Hz	10FL3 etc.
31	USB filter at 2MHz	10FL1 etc.
32	USB filter at 10MHz+5Hz	10FL1 etc.
33	8kHz filter at 2MHz	10FL6 etc.
34	8kHz filter at 10MHz+5Hz	10FL6 etc.
35	16kHz atten. at 2MHz	10RLA N/P etc.
36	16kHz atten. at 10MHz+5Hz	10RLA N/P etc.

Table 3.2 (continued)

BITE No.	Test	Notes
----------	------	-------

Tests 37 to 56 inc. are overall signal path tests using the inbuilt noise generator to check the receiver gain level over the frequency range with WIDEBAND selected (i.e. with the narrowband preselector bypassed on suffix /A receivers).

Each test is carried out at two different I.F. bandwidths (and second loop settings) to allow for a fault in one of them. The test must fail at both bandwidths to indicate a gain fault. Faults only occurring at certain frequencies indicate faults prior to the first mixer 41IC1, or faults in the synthesiser at the corresponding points (note that a low synthesiser drive level will not necessarily indicate fail since it tends to increase the noise level generated). If all tests fail, a serious fault in the signal path or synthesiser is most likely. The front panel meter indicates the test level and reads approximately half full scale when the level is correct. A fault producing approximately 20-30dB attenuation will produce a fail indication.

37	70kHz gain (8kHz filter)	
38	70kHz gain (+5Hz, 16kHz filter)	
39	126kHz gain (8kHz filter)	
40	126kHz gain (+5Hz, 16kHz filter)	
41	250kHz gain (8kHz filter)	
42	250kHz gain (+5Hz, 16kHz filter)	
43	500kHz gain (8kHz filter)	
44	500kHz gain (+5Hz, 16kHz filter)	
45	1000kHz gain (8kHz filter)	
46	1000kHz gain (+5Hz, 16kHz filter)	
47	2000kHz gain (8kHz filter)	
48	2000kHz gain (+5Hz, 16kHz filter)	
49	4000kHz gain (8kHz filter)	
50	4000kHz gain (+5Hz, 16kHz filter)	
51	8000kHz gain (8kHz filter)	
52	8000kHz gain (+5Hz, 16kHz filter)	
53	15000kHz gain (8kHz filter)	
54	15000kHz gain (+5Hz, 16kHz filter)	
55	29998kHz gain (8kHz filter)	
56	29998kHz gain (+5Hz, 16kHz filter)	

Table 3.2 (continued)

BITE No.	Test	Notes
----------	------	-------

Tests 57 to 81 inc. are overall signal path tests using the inbuilt noise generator to check the receiver gain level over the frequency range with the narrowband preselector selected.

These tests therefore are only available on suffix /A receivers, otherwise they display SPARE (this is determined by preset option switch number 6). Adequate time must be allowed for the narrowband R.F. preselector to tune to its correct position (up to 1 second), before the test result displayed is valid. Tests are performed at the extreme ends and the middle of each preselector range apart from the first which is a fixed low pass filter. The frequencies are the preselector tracking points used during alignment and thus the preselector can be roughly aligned using these tests. Failure of all the tests on a particular range indicates a total range failure. Part failure generally indicates faulty range tracking. Failure of all tests (when tests 37 to 56 have passed) generally indicates a major preselector or preselector switching fault. The front panel meter indicates the test level and reads approximately half full scale when the level is correct. A fault producing approximately 20-30dB attenuation will produce a fail indication.

57	70kHz gain	Range 9
58	158kHz gain	Range 8
59	250kHz gain	Range 8
60	292kHz gain	Range 8
61	315kHz gain	Range 7
62	510kHz gain	Range 7
63	585kHz gain	Range 7
64	620kHz gain	Range 6
65	1000kHz gain	Range 6
66	1170kHz gain	Range 6
67	1240kHz gain	Range 5
68	2140kHz gain	Range 5
69	2430kHz gain	Range 5

Table 3.2 (continued)

BITE No.	Test	Notes
70	2600kHz gain	Range 4
71	4200kHz gain	Range 4
72	4900kHz gain	Range 4
73	5100kHz gain	Range 3
74	8600kHz gain	Range 3
75	9800kHz gain	Range 3
76	10300kHz gain	Range 2
77	15500kHz gain	Range 2
78	19500kHz gain	Range 2
79	20400kHz gain	Range 1
80	25000kHz gain	Range 1
81	29500kHz gain	Range 1

Tests 82 to 97 inc. are spare.

Test 98 is used to display internal preset option switch setting numbers that are on.

Test 99 is used to display the issue number of the receivers operating system.

3.4 Channelised Operation

Ninety-nine non-volatile memories are provided for channel storage. In each memory, tune frequency, BFO offset, reception mode, RF sensitivity, AGC setting, bandwidth and auxillary antenna setting can be stored. Memories can be interrogated (viewed), loaded, modified, shifted or cleared without disturbing the signal being received. These operations often mean that the displayed channel is not that to which the receiver is tuned. This state is indicated by flashing of the two 'decimal points' in the CHANNEL display. During modification of channel data, the free tuning channel 00 is used as an intermediate temporary store for the data being altered or shifted. Therefore channel 00 must not be used as the receiving channel if reception is not to be disturbed. Similarly the channel chosen for reception should not be used during channel modifications etc.

Channel memories can be interrogated by pressing <CHANNEL> and entering the channel number using the numeric keys. The number can also be altered using the main control knob. Channel mode has to be selected before operations which involve modification of channel memories. The contents of the selected memory are thus displayed for checking before being altered.

The channels stored can be received as required and can also be scanned (section 3.5) or the frequencies stored can be used as limits for frequency sweeping (section 3.6). The following examples detail most of the commonly required channel operations concerning direct reception and contents alteration.

Example 3.12 Storing a Received Signal Setting

To store the settings of the receiver when tuned to a desired signal in RECALL mode (spare channels are known to be in the vicinity of, say, channel 9).

Press <CHANNEL>, <0>, <9>. The present contents are displayed and the decimal points flash to indicate that this is not the channel being received. If the channel is clear (blank display) or contains settings no longer required, it may be used to store the new

settings. Otherwise, turn the main control knob to select a more suitable channel.

When a suitable channel is found, press <STORE> to load the channel memory.

Press <RECALL> to return to the normal tuning mode.

Note that channel 00 is the free tuning channel and <STORE> copies all data from this to the channel displayed in CHANNEL mode, overwriting its previous contents. To ensure that channels are not accidentally overwritten, <STORE> only operates if CHANNEL mode is first selected with the <CHANNEL> key, allowing the original contents to be checked before being modified.

Example 3.13
Receiving on a Stored Channel

(with tuning controls enabled)

To initially receive on channel 91's settings but with the ability to adjust the settings if required (for example to tune the receiver to allow for changes in the received signal's frequency).

Press <CHANNEL>, <9>, <1>, <RECEIVE>, <RECALL>.

The initial commands ensure that the receiver is first tuned to channel 91. The settings are then copied into, and the receiver tuned to the free tuning channel 00.

Example 3.14
Receiving on a Stored Channel

(with tuning controls locked out)

To receive on channel 29's settings with the tuning controls locked out to prevent any alteration of the settings.

Press <CHANNEL>, <2>, <9>, <RECEIVE>.

RECEIVE mode is initially used in this way if the receiver has to remain tuned to a specific frequency for a long period of time.

Example 3.15
Modifying Channel Settings

(without disturbing the received signal)

Starting with channel 29 being received (as in example 3.14), to modify channel 12's settings for later use without breaking into the signal being received.

Press <CHANNEL>, <1>, <2>, <TUNE>.

Channel 12's present settings are copied into the free tuning channel 00. The CHANNEL 'decimal points' will flash to indicate 00 is not the channel being received.

Modify the settings using the controls as described in sections 3.2.2, 3.2.3, 3.2.4 and 3.2.8. Note that these modifications have no effect on the received signal.

Press <CHANNEL> and the display shows channel 12 and its original contents.

Press <STORE> to copy the new settings into channel 12, overwriting the original settings. Note that the new settings can be stored in a different channel (apart from 29 in this case!), by using the numeric keys or main control knob to select a channel other than 12 or 29 before <STORE> is pressed.

Note that <TUNE> always copies settings from the displayed channel into the free tuning channel 00. Compare this with <RECALL> which always copies the actual received settings. Pressing <CHANNEL> directly after these, initially displays the channel which was originally displayed or received respectively.

During more complicated memory modifications whilst receiving on a fixed channel, the received signal may require the receiver to be retuned slightly or the number of the received channel may simply be forgotten. To enable rapid re-adjustment press <RECALL>.

To determine the original receive channel number then press <CHANNEL>.

To return to fixed reception on that channel finally press <RECEIVE>.

Example 3.16
Shifting Memory Contents

To copy the settings in memory 67, without alteration, into channel 88. This may be necessary to modify the order in which frequencies are scanned or, to alter the frequency limit of a sweep sequence with new settings already in memory 67.

Press <CHANNEL>, <6>, <7>, <TUNE> to copy channel 67 settings into the free tuning channel 00.

Press <CHANNEL>, <8>, <8>, <STORE> to copy these settings from 00 to channel 88.

The settings in 67 are thus copied into 88. Note that if required, they may be modified whilst in 00. Note the contents of the originating channel 67 are not altered.

Example 3.17
Clearing a Channel Memory

To clear channel memory 78 of its present contents since, for example, it is no longer required and its frequency setting must not be retained for security reasons. Note that a cleared channel is also more obviously useable for storing new settings.

Starting in RECALL or TUNE modes with a frequency display (BFO and AUXILLARY ANTENNA LEDs both off).

Press <0> and turn the main control knob slightly to enter 'zero' frequency. The frequency display will go blank (ie. 00 will become a clear channel).

Press <CHANNEL>, <7>, <8>, <STORE> to copy a clear channel's settings into channel 78.

Note that a clear channel effectively contains a frequency below 10kHz, usually 'zero'. The other channel settings stored are not cleared and will reappear if a valid frequency is loaded into the channel (using the the process in Example 3.15). The original frequency of a channel will however be totally lost when a channel is cleared. Trying to receive on a cleared channel will provide a muted output.

3.5 Scanning Operation

Any number of the stored channels (except the free tuning channel 00) can be scanned, in channel number order, with adjustable dwell and hang times. The dwell time is the period for which the receiver stays on each channel. This period can be set in the range 0.0 to 9.9 seconds (0.1 second increments).

If MUTE on is selected and a signal above the audio mute threshold is present on the channel being received, the receiver will halt on that channel and remain there for the hang period after the signal ceases or goes below the threshold level. This period can be set in the range 0 to 9 seconds (one second increments). However, for the scan halt to operate correctly, each scanned channel has to have one of the three AGC on modes set (AUDIO, SLOW or FAST) and the decay times of the AGC will add to the hang period. If zero or a short hang period (less than one or two seconds) is required, AGC FAST must be used which only adds a few hundred milliseconds to the displayed hang period.

The threshold level is set by the I.F. GAIN / MUTE LEVEL control. The setting of this is displayed with the meter on its COR setting. When AGC is on, the calibration of the meter on COR is equivalent to that on RF and corresponds to signals of about 0 to +50dBuV emf for zero to full deflection. The I.F. GAIN / MUTE LEVEL control should therefore be adjusted to obtain the same meter reading on COR as a signal at the required threshold level produces with the meter on RF.

The scan channel sequence can also be stepped on or back by the main control knob. If a dwell of 0.0 seconds is set, the knob has sole control of the sequence and thus provides 'tuning by channel'.

The rear panel REMOTE connector has a HOLD SCAN/SWEEP input line. Connecting this line to ground holds the receiver at the channel being scanned at that moment. Removing the connection to ground causes the receiver to immediately step on to the next channel. This input line can therefore be used, in conjunction with external signal detecting equipment, to halt the scan when a specific type of signal is received. It can also be used, in conjunction with an external switch to ground, to scan channels at a rate determined by that switch.

The scanning facility is most suitable for monitoring randomly spaced frequencies where the mode settings on each frequency are not necessarily the same or the frequencies in order. For large

numbers of equally spaced frequencies which have the same mode settings and which are in order of frequency, the sweep function is more suitable (section 3.6).

The following examples show commonly used scanning operations. Scanning can be started when in any mode by pressing <SCAN>. Note however that at least two channels must be set to be scanned. Also note that if MUTE is on and a signal above the threshold is present before <SCAN> is pressed, scanning of the desired channels will not start until the signal ceases or the scan is forced to move on by turning the main control knob.

Example 3.18

Displaying Scan Parameters / Channel Numbers

Press <DWELL>. The FREQUENCY kHz display will show the dwell and hang times. For example 1.2 - 8 SEC indicates a dwell of 1.2 seconds and a hang of 8 seconds.

Turn the main control knob either way and this will step through the numbers of the channels set to be scanned (shown in the CHANNEL display). The SCAN CHANNEL LED will also flash to indicate that the displayed channel number is set to be scanned. If it does not flash, this indicates that no channels are set (the invalid tone will also sound as the knob is turned if the keyboard sounder is enabled).

Example 3.19

Removing Channels from the Scan Sequence

Proceed as in Example 3.18 using the main control knob.

Press <SCAN CHANNEL> whilst displaying the number of the channel to be removed from the scan sequence. When it is removed, the SCAN CHANNEL LED will stop flashing.

This is the easiest way of removing channels from the scan sequence (it can also be done in

CHANNEL mode) since it only displays scanned channel numbers. If required, all channels can be rapidly removed with the invalid tone sounding as soon as non are left.

If a channel is removed in error, it can be reset by pressing <SCAN CHANNEL> again before turning the control knob to select another number (as the removed channel number will not be displayed again in this mode).

Example 3.20
Setting Dwell and Hang Periods

To set, for example, a dwell period of 3.5 seconds and a hang period of one second.

Press <DWELL>, <3>, <5>, <1>. The numbers enter right to left. Note that dwell and hang cannot be entered separately.

Example 3.21
Setting Channels to be in the Scan Sequence

To enter channels into the scan sequence (23 and 45 for example) which are not already set to be scanned.

Press <CHANNEL>, <2>, <3>, <SCAN CHANNEL>.

Press <4>, <5>, <SCAN CHANNEL>.

In each case the SCAN CHANNEL LED will flash when the channel is set to be scanned. Note that channels already in the sequence can be removed in the same way (see also Example 3.19).

Example 3.22
Typical Scanning Useage

A typical use would be to monitor a split frequency simplex conversation using frequencies stored in say, channels 23 and 45.

Proceed as in Examples 3.19 and 3.21 to ensure that channels 23 and 45 are the only channels in the scan sequence.

Press <MUTE> if the MUTE LED is off.

Press <AGC> repeatedly to select FAST.

Press <METER> repeatedly to select COR and use the meter as a guide to set up the scan halt threshold level with the <I.F. GAIN / MUTE LEVEL> control. The meter reading should equal that obtained from a signal just at the threshold level with the meter set to RF. Signals which then give meter readings higher than that displayed on COR, will then cause the scan to halt.

Press <DWELL>, <0>, <5>, <0>, <SCAN>.

Example 3.22 sets the receiver scanning the channels which contain the frequencies used in the two way transmission. A short dwell time ensures that the start of the transmission is not missed no matter which frequency is used first. The short hang time ensures that the receiver tunes to the other half of the conversation when the first half ceases.

In general the dwell period is kept as short as possible, just being long enough to allow reliable detection or recognition of desired signals by the chosen means (i.e. by the scan halt circuitry, by operator's 'ear' or by ancillary equipment). The hang period is selected to suit the type of communication being monitored and is usually kept very short for split frequency simplex. Several seconds are required for single frequency simplex to ensure the receiver stays on the same frequency to monitor both sides of the conversation. SSB signals usually need AUDIO or SLOW AGC to be selected. Note that these AGC decay times add about one or two seconds to the

hang period and this has to be taken into account when monitoring SSB split frequency simplex transmissions. This lengthening of the hang period is desirable because SSB signals naturally fall below the threshold level during the normal one to two second pauses in speech. A very short hang period in this circumstance would therefore cause erratic channel switching.

Example 3.23
Tuning by Channel

Proceed as in previous examples to set the channels which are to be scanned.

Press <DWELL>, <0>, <0>, <0> to enter a dwell period of 0.0 seconds (the hang period is not significant).

Press <SCAN>. Turning the main control knob now just tunes the receiver to the channels in the scan sequence.

Manual tuning by channel is useful in circumstances where rapid selection of a small number of frequencies is required, especially if each also requires different mode, bandwidth, antenna selection etc settings.

3.6 Sweeping Operation

The receiver can automatically sweep tune between the frequencies stored in any two adjacent channel memories (except the free tuning channel 00). The rest of the receiver settings are as stored in the lower numbered of the two adjacent memories. This is called the 'sweep start channel' and can be set from the front panel in the range 01 to 98. The sweep can be in ascending or descending frequency and automatically repeats.

Tuning proceeds in the steps set as the rate (see Example 3.4), the receiver remaining on each frequency step for the selected dwell period (see Example 3.20).

For steps of 5kHz or greater, if MUTE on is selected and a signal above the audio mute threshold is present on the frequency being received, the receiver will halt and remain there for the hang period after the signal ceases or goes below the threshold level. This period can be set in the range 0 to 9 seconds (one second increments). However, for the sweep halt to operate correctly, one of the three AGC on modes (AUDIO, SLOW or FAST) must be set in the lower numbered channel. Since the decay times of the AGC will add to the hang period, if zero or a short hang period (less than one or two seconds) is required, AGC FAST must be used which only adds a few hundred milliseconds to the displayed hang period.

The threshold level is set by the I.F. GAIN / MUTE LEVEL control. The setting of this is displayed with the meter on its COR setting. When AGC is on, the calibration of the meter on COR is equivalent to that on RF and corresponds to signals of about 0 to +50dBuV emf for zero to full deflection. The I.F. GAIN / MUTE LEVEL control should therefore be adjusted to obtain the same meter reading on COR as a signal at the required threshold level produces with the meter on RF.

The sweep channel sequence can also be stepped on or back by the main control knob. If a dwell of 0.0 seconds is set, the knob has sole tuning control of the sequence and thus provides tuning over a predetermined range only.

The rear panel REMOTE connector has a HOLD SCAN/SWEEP input line. Connecting this line to ground holds the receiver at the frequency being received at that moment. Removing the connection to ground causes the receiver to immediately step on to the next frequency. This input line can therefore be

used, in conjunction with external signal detecting equipment, to halt the sweep when a specific type of signal is received. It can also be used, in conjunction with an external switch to ground, to step at a rate determined by that switch.

The sweep facility is most suitable for monitoring large numbers of equally spaced frequencies which have the same mode settings and which are in order of frequency. The scan function is more suitable for monitoring randomly spaced frequencies where the mode settings on each frequency are not necessarily the same or the frequencies in order (section 3.5).

The following examples show commonly used sweeping operations. Sweeping can be started when in any mode by pressing <SWEEP>. Note however that both of the adjacent channel memories used must contain frequencies which are separated by greater than the step (RATE) frequency.

Example 3.24

Displaying Sweep Parameters / Start Channel

Press <DWELL>. The FREQUENCY kHz display will show the dwell and hang times. For example 1.2 - 8 SEC indicates a dwell of 1.2 seconds and a hang of 8 seconds.

Press <RATE>. The CHANNEL display will show the number of the present sweep start channel and the FREQUENCY kHz display will show the step size. Note that this is the same step size as for manual tuning (00.00 to 99.99kHz) except that 00.00 is invalid for sweep tuning.

To alter the dwell and hang periods, proceed as in Example 3.20. To alter the step size, proceed as in Example 3.4.

Example 3.25
Setting the Sweep Start Channel

To select, for example, channel 27 as the sweep start channel.

Press <CHANNEL>, <2>, <7>, <START CHANNEL>.

The START CHANNEL LED will flash (in CHANNEL mode), to indicate that the displayed channel is now the sweep start channel. The number of the previous sweep start channel is lost.

Whilst still in CHANNEL mode ensure that the contents of the start channel and the next highest numbered channel (28) both contain frequencies which are separated by greater than the step size.

Example 3.26
Typical Sweeping Usage

A typical use would be to check for activity in the whole of say, 26965 to 27405kHz, in 10kHz steps, with the receiver set for AM reception. The step is greater than 4.99 kHz and therefore the sweep can be halted if a signal is found.

Press <RECALL> and tune the receiver to 26965kHz, AM mode, 3kHz bandwidth, MAX RF SENS., AGC FAST and 3kHz I.F. BANDWIDTH.

Press <CHANNEL>, <2>, <7>, <STORE>.

Press <RECALL> and tune the receiver to 27405kHz.

Press <CHANNEL>, <2>, <8>, <STORE>.

Proceed as in Example 3.25 to set 27 as the start channel.

Press <MUTE> if the MUTE LED is off.

Press <METER> repeatedly to select COR and use the meter as a guide to set up the sweep halt level with the <I.F. GAIN / MUTE LEVEL>

control. The meter reading should equal that obtained from a signal just at the threshold level with the meter set to RF. Signals which give meter readings higher than that displayed on COR, will then cause the sweep to halt.

Press <DWELL>, <0>, <1>, <5>, <SWEEP>.

Example 3.26 sets the receiver constantly sweeping between the two frequencies in 10kHz steps. The very short dwell time minimises the total time required to monitor all the channels (approximately 5 seconds). The moderately long hang time ensures that the receiver does not rapidly tune away from a signal which may have only temporarily gone below threshold level. For further information about dwell and hold times, see the end of section 3.5.